

THIS DRAWING IS UNPUBLISHED. RELEASED FOR PUBLICATION
 © COPYRIGHT 2011 BY TYCO ELECTRONICS CORPORATION. ALL RIGHTS RESERVED.

LOC	DIST	REVISIONS					
DW		P	LTR	DESCRIPTION	DATE	DWN	APVD
		B2		REVISED (ECR-13-014160)	06JAN14	S.C.	H.L.

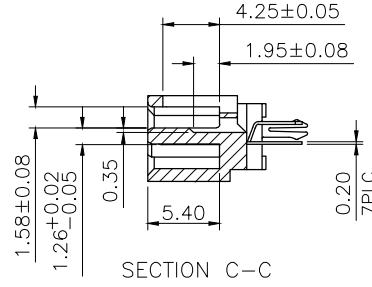

- NOTE:
- MATERIAL:
 - 1.1 HOUSING: PA9T WITH 30% GF, UL 94V-0, COLOR: SEE TABLE
 - 1.2 CONTACT: BRASS
 - 1.3 BOARDLOCK: BRASS
 - FINISH:
 - 2.1 CONTACT: 0.381um[15u"] GOLD PLATED ON CONTACT AREA. 2.54um[100u"] MIN. MATTE-TIN ON SOLDER TAIL. 1.27um[50u"] MIN. NICKEL UNDERPLATED OVERALL
 - 2.2 BOARDLOCK: 2.54um[100u"] MIN. MATTE-TIN PLATED OVERALL. 1.27um[50u"] MIN. NICKEL UNDERPLATED OVERALL
 - WAVE SOLDER CAPABLE TO 265°C PER TE SPEC. 109-202, CONDITION B.

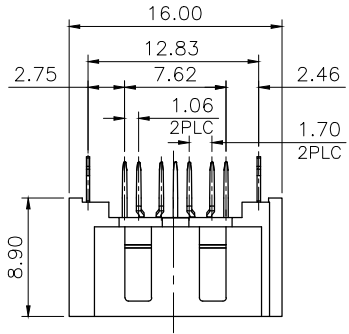
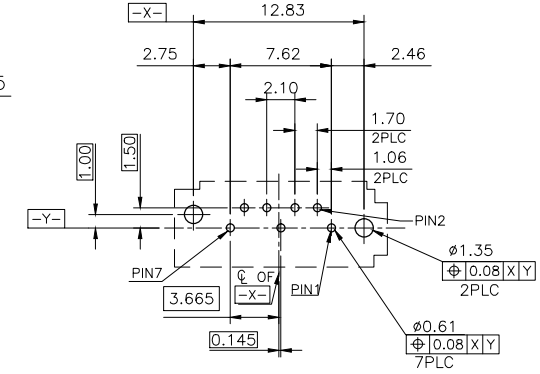
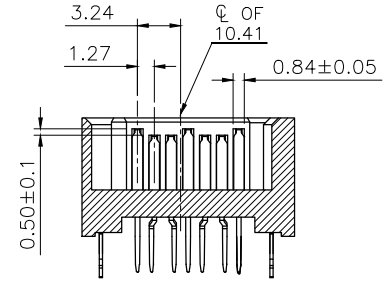
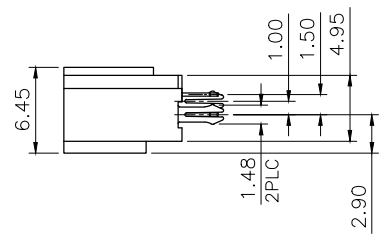
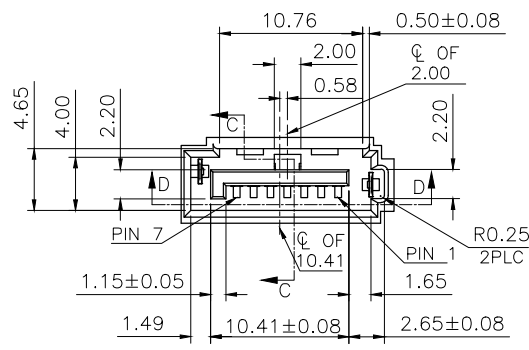

RECOMMENDED PCB LAYOUT
 THICKNESS: 1.6mm; TOLERANCE: ±0.05

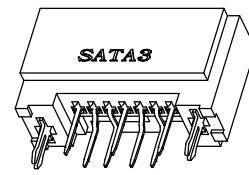
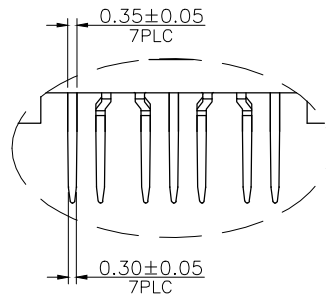
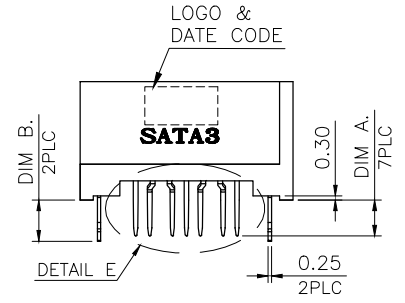

OBSOLETE	2.50	2.10	BLUE(287C)	2041346-1
			RED(186C)	2041346-4
ACTIVE	3.10	2.70	RED(184C)	2041346-3
			BLACK	2041346-2
			BLUE(287C)	2041346-1
STATUS	DIM B.	DIM A.	HOUSING COLOR	PART NUMBER

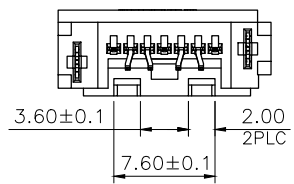

THIS DRAWING IS A CONTROLLED DOCUMENT.		DWN J. LAI 28JUN2011	TE Connectivity	
DIMENSIONS: mm		CHK S. CHIEN 28JUN2011		
TOLERANCES UNLESS OTHERWISE SPECIFIED:		APVD W. KODAMA 28JUN2011	NAME	
0 PLC ± - 1 PLC ± 0.3 2 PLC ± 0.2 3 PLC ± 0.15 4 PLC ± - ANGLES ± 3°		PRODUCT SPEC 108-57857	SIGNAL SATA3, 7P, DIP TYPE	
MATERIAL SEE NOTE	FINISH SEE NOTE	APPLICATION SPEC	SIZE A3	CAGE CODE 00779
		WEIGHT 0.782 GRAMS	DRAWING NO C=2041346	RESTRICTED TO
		CUSTOMER DRAWING	SCALE	SHEET 1 of 2
				REV B2

LOC	DIST	REVISIONS					
DW		P	LTR	DESCRIPTION	DATE	DWN	APVD
				SEE SHEET 1.			

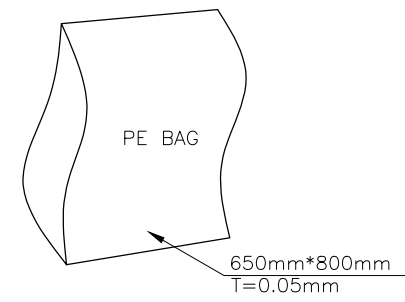
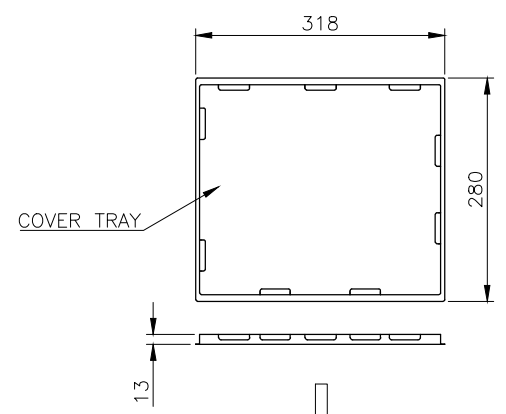

NOTES:
 PACKING MATERIAL MET TEC 138-702.
 1. MATERIAL:
 COVER TRAY: PVC.
 BOTTOM TRAY: PVC.
 BAG: PE.
 SHIPPING CARTON: CORRUGATED FIBER.
 2. DIMENSION:
 COVER TRAY: SEE DWG.
 BOTTOM TRAY: SEE DWG.
 BAG: SEE DWG.
 SHIPPING CARTON: SEE DWG.

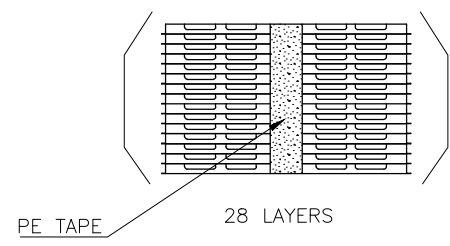
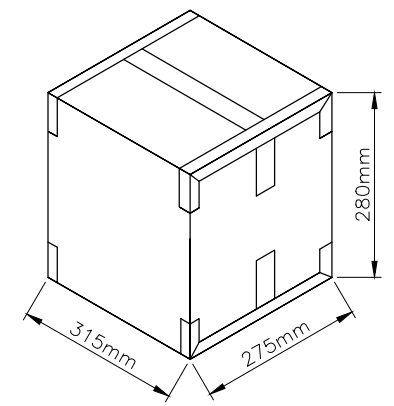
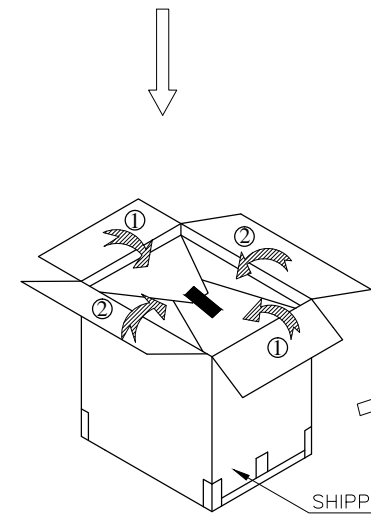
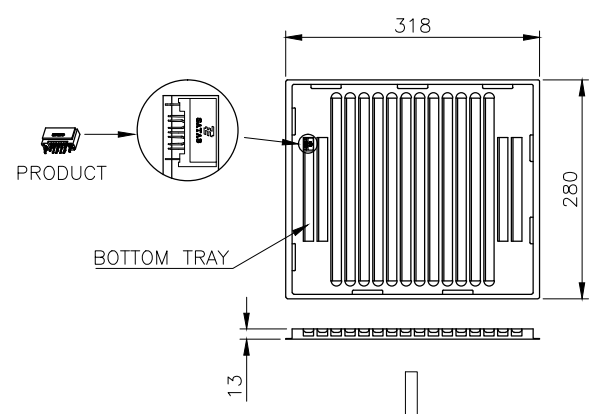

					2041346-4
					2041346-4
					2041346-3
					2041346-2
					2041346-1
GROSS WEIGHT	5.45KG	NET WEIGHT	4.38KG	PCS/ TRAY	200
				TRAY/ BOX	28
				PCS/ BOX	5600
					PART NUMBER

THIS DRAWING IS A CONTROLLED DOCUMENT.		DWN	TE Connectivity SIGNAL SATA3, 7P, DIP TYPE		
DIMENSIONS: mm		CHK			
TOLERANCES UNLESS OTHERWISE SPECIFIED:		APVD			
0 PLC ± - 1 PLC ± 0.3 2 PLC ± 0.2 3 PLC ± 0.15 4 PLC ± - ANGLES ± 3°		PRODUCT SPEC			
MATERIAL	FINISH	APVD	NAME	SIZE	CAGE CODE
		PRODUCT SPEC		A3	00779
		APPLICATION SPEC		DRAWING NO C=2041346	
		WEIGHT		RESTRICTED TO	
CUSTOMER DRAWING			SCALE	SHEET 2 of 2	REV B2